

PRAB GUARDIAN™ COOLANT RECYCLING SYSTEM

PROVEN TO REDUCE YOUR COOLANT WASTE UP TO 90%

The Effective Solution to Coolant Management Problems

PRAB's Guardian Coolant Recycling System is a centralized, economical solution to the high costs associated with maintaining water-based coolants and washwater in the metalworking industry. The Guardian system recycles used coolants, reducing waste fluids by up to 90%, and eliminates concerns about wastewater haul-away liabilities. Everything you need for centralized coolant recycling is included with the Guardian. Each turnkey system is designed for easy installation, quick start-up, and simple, efficient operation. PRAB backs every Guardian system with a 100% performance guarantee.

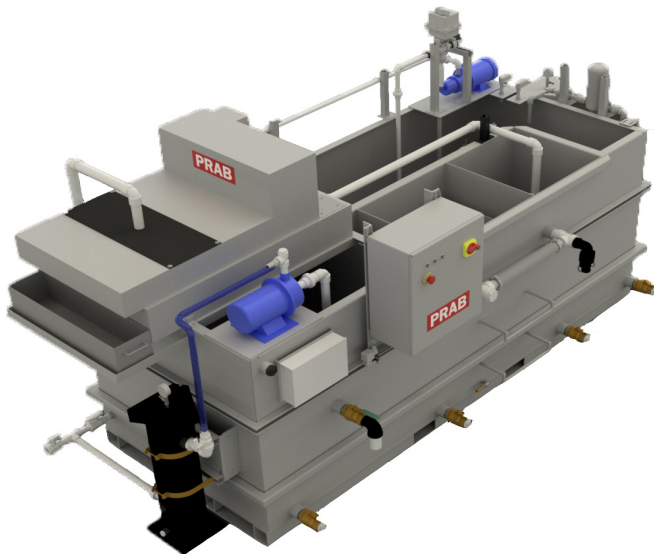

Guardian Coolant Recycling System

Documented Results Achieved by PRAB Customers:

- Reduced new fluid purchases up to 75%
- Decreased fluid disposal costs by approximately 90%
- Extended tool life by up to 25%
- Reduced machine downtime by an average of 50%
- Improved surface finish by an average of 25%

System Features:

- Processes up to 1,500 gallons of coolant per hour with standard configurations; larger capacity is available upon request
- Removes tramp oils and reduces up to 75% of new fluid purchases
- Reduces hazardous waste disposal costs up to 90%
- Typically generates system payback in 6-9 months
- Minimizes operator involvement and training
- Achieves tighter coolant clarity tolerances with optional polishing filter
- Extends tool life and saves up to 25% in new tool purchases
- Removes free-floating oils to 0.1% or less
- Prevents rancidity with continuous overflow
- Purges coalescing media or solids and sludge with automatic air sparger

Backed by the **PRAB Difference**



PRAB GUARDIAN™ COOLANT RECYCLING SYSTEM

EXTENDS TOOL LIFE BY UP TO 25%

Configuration Packages

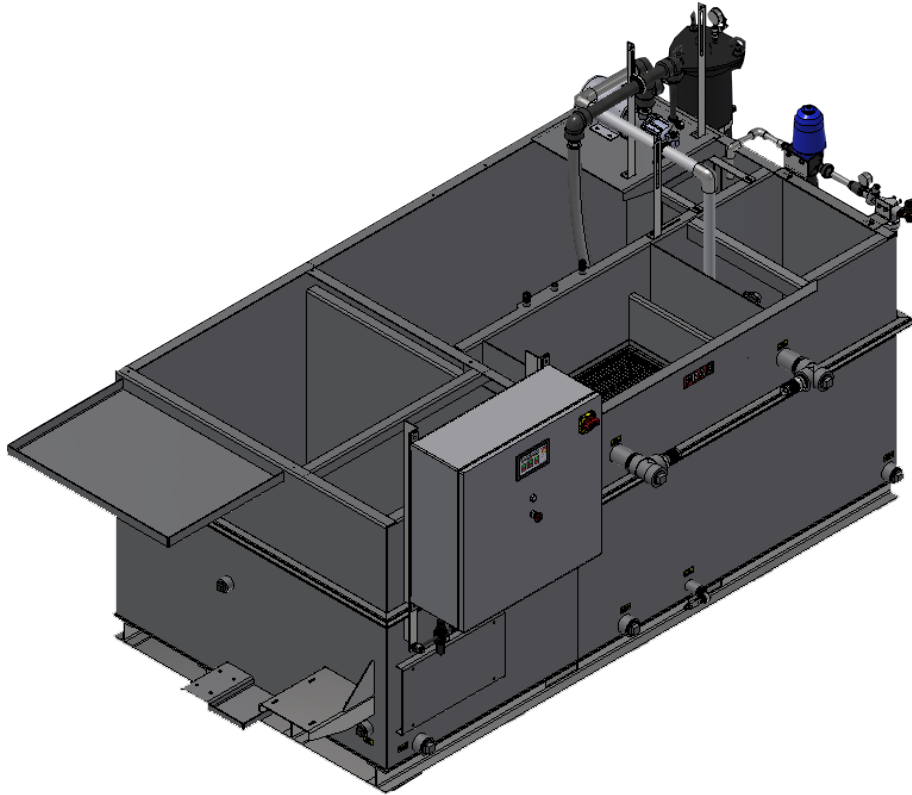

Base Package

- An inlet basket strainer
- Dirty and clean coolant tanks
- A Tramp Oil Separator with a coalescing media pack
- A floating skimmer assembly
- Steel oil weirs, manifolded together on exterior of the tank
- An automatic air sparging system
- A coolant make-up system
- Control Panel
 - Allen Bradley components
 - HMI
- Voltage: 460/3/60
 - Other voltage options available: contact factory for pricing and lead time

Backed by the **PRAB Difference**

PRAB GUARDIAN™ COOLANT RECYCLING SYSTEM

EXTENDS TOOL LIFE BY UP TO 25%

Configuration Packages Cont.

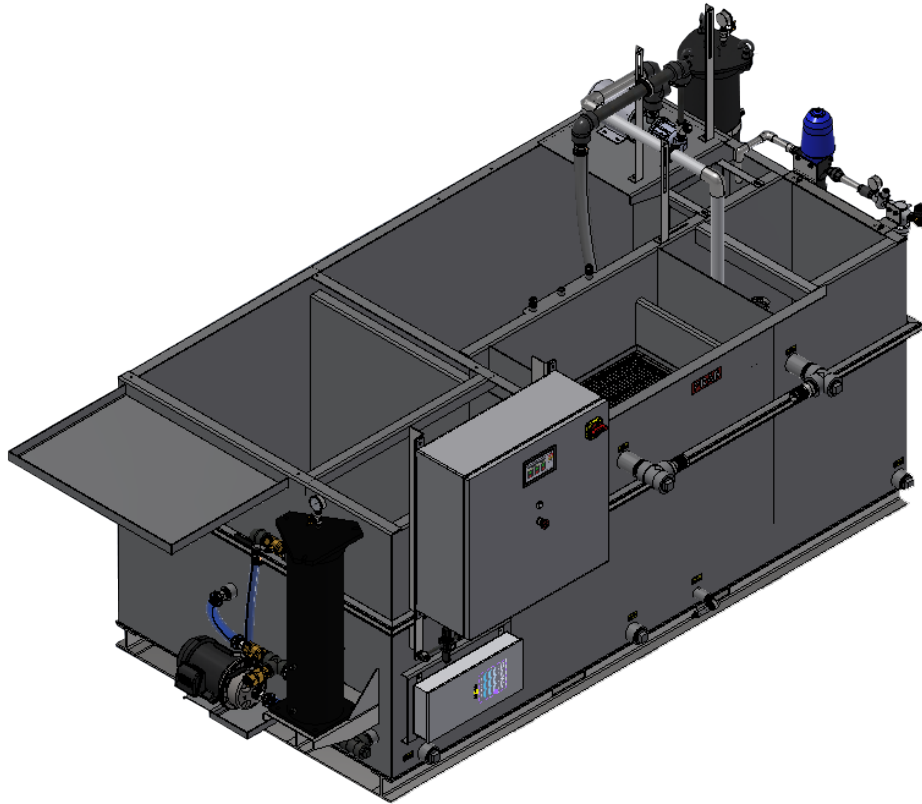

Standard Package

- An inlet basket strainer
- Dirty and clean coolant tanks
- A Tramp Oil Separator with a coalescing media pack
- A floating skimmer assembly
- Steel oil weirs, manifolded together on exterior of the tank
- An automatic air sparging system
- A coolant make-up system
- Control Panel
 - Allen Bradley components
 - HMI
- Voltage: 460/3/60
 - Other voltage options available: contact factory for pricing and lead time

Additional features included in the Standard Configuration:

- Coolant Manager: Ozone Generator
- Polishing Filter Assembly: typically 20-micron rated filter

Backed by the **PRAB Difference**

PRAB GUARDIAN™ COOLANT RECYCLING SYSTEM

EXTENDS TOOL LIFE BY UP TO 25%

Configuration Packages Cont.

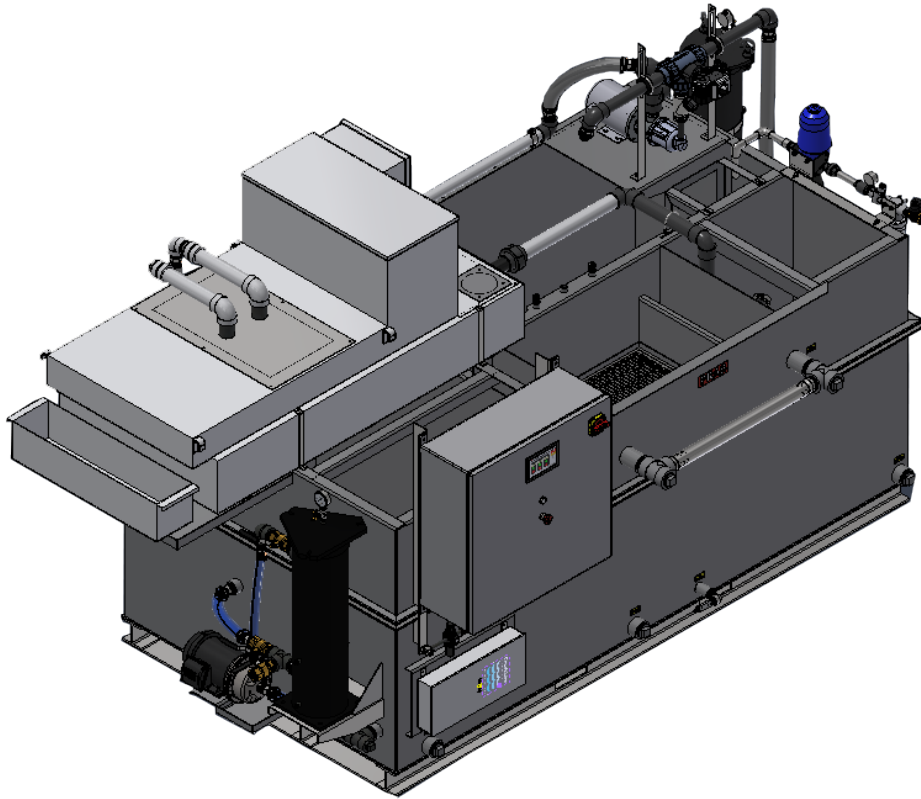

Deluxe Package

- An inlet basket strainer
- Dirty and clean coolant tanks
- A Tramp Oil Separator with a coalescing media pack
- A floating skimmer assembly
- Steel oil weirs, manifolded together on exterior of the tank
- An automatic air sparging system
- A coolant make-up system
- Control Panel
 - Allen Bradley components
 - HMI
- Voltage: 460/3/60
 - Other voltage options available: contact factory for pricing and lead time

Additional features included in the Deluxe Configuration:

- Coolant Manager: Ozone Generator
- Polishing Filter Assembly: typically 20-micron rated filter
- Dirty Coolant Transfer System
- Paper Bed Filter: with 10-micron rated filter media
 - Note: Inlet Basket Strainer has been removed in lieu of the paper bed filter

Backed by the **PRAB Difference**

PRAB GUARDIAN™ COOLANT RECYCLING SYSTEM

REDUCES NEW COOLANT PURCHASES UP TO 75%

Easy to Operate & Maintain

The PRAB Guardian Coolant Recycling System is furnished with an automatic air sparger to maintain clean coalescing media, a high level tramp-oil switch that turns the system off when the tramp-oil container is full, thus eliminating the potential for tramp-oil spillage, and a full control panel for ease of operation. Backed by a 100% Performance Guarantee.

Model	Processing Rate Gallons Per Minute	Dirty/Clean Tank Capacity (Gallons)	Overall Length	Overall Width	Overall Height
HG400	10	200/200	89"	73"	72.5"
HG600	10	300/300	126"	74.5"	76.6"
HG800	15	400/400	154"	76.5"	78.8"
HG1200	15	600/600	168.6"	77.5"	86.1"
HG1600	25	800/800	179.8"	90.3"	94"
HG2000	25	1000/1000	174"	91.3"	101"
HG4000	25	2000/2000	250"	91"	148"

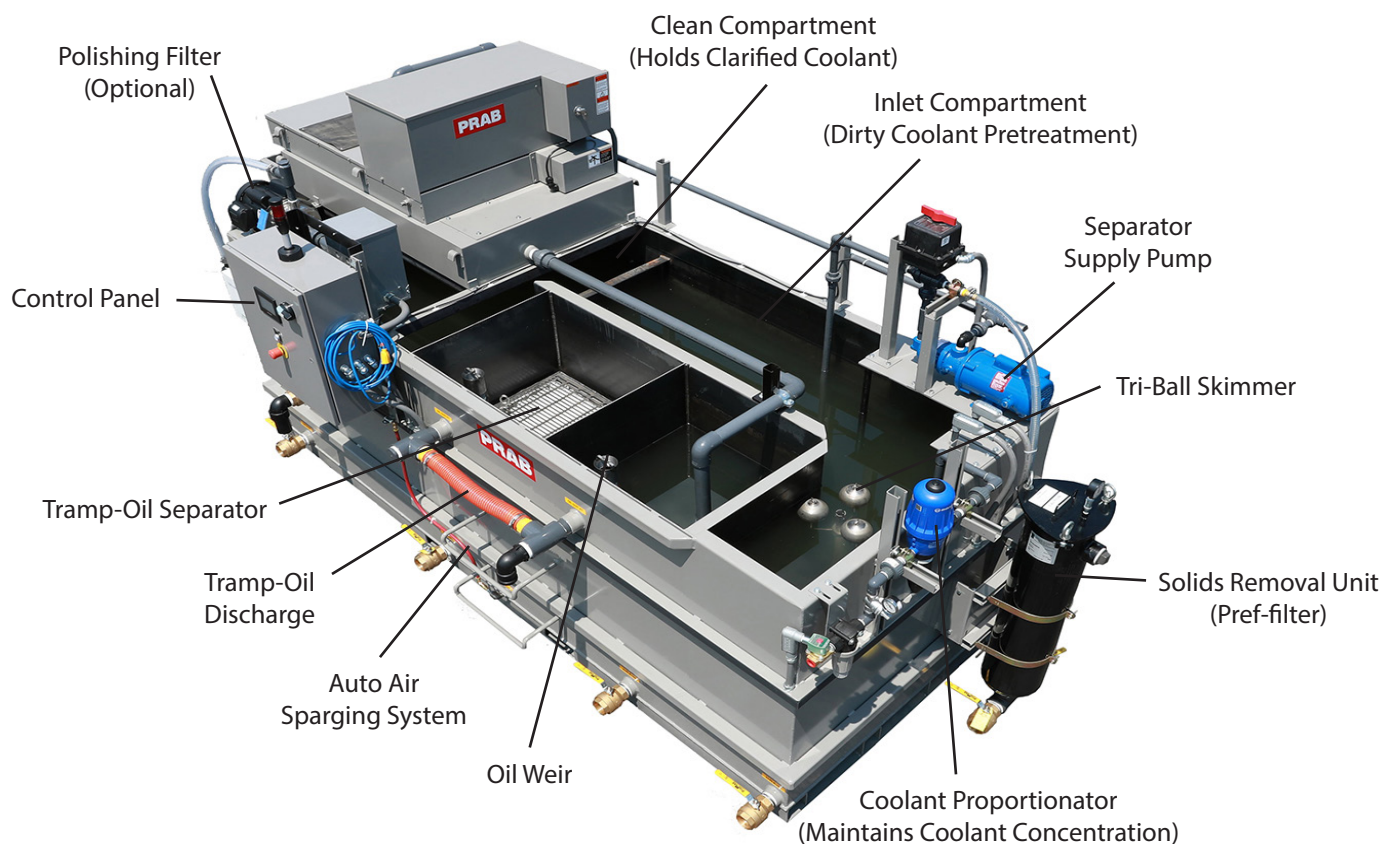

Contact us to **request a quote** today

5801 East N Avenue, Kalamazoo, MI 49048

Phone: 1-800-968-7722 | Email: sales@prab.com | Website: prab.com

