

PRAB PAPER BED FILTERS

PROVEN TO REDUCE MACHINE DOWNTIME BY UP TO 50%

Low-Profile, Cost-Effective Solutions for Solids Filtration

PRAB offers a complete line of paper bed filters that provide long-term solutions for solids filtration, with or without magnetic separation- perfect for grinding applications. Filtered fluid can be reused or recycled, lowering your operational costs.



Standard Paper Bed Filter



Magnetic Paper Bed Filter

Top Features & Benefits:

- Can be used for both ferrous and non-ferrous metals
- Disposable paper filter media is available in a variety of grades to meet your specific requirements
- Filter surface is automatically indexed only when needed
- Automatic self-cleaning and self-monitoring system
- Oil and water soluble applications
- Prolongs coolant and tool life
- Removal of particulate down to 5 micron level (standard unit is 25 microns)
- Improves surface finish of the component part
- Variety of sizes are available ranging from 5-210 gpm
- Perfect for grinding applications

PRAB Customers have experienced an increase in average tool life from properly filtered fluid, as much as:

- 209% for drills
- 78% for turning tools
- 66% for form tools
- 47% for boring tools
- 26% for reamers

Backed by the **PRAB Difference**



PRAB PAPER BED FILTERS

QUICK SHIP: MOST UNITS SHIP IN 5-7 DAYS

Flow Rate Charts

The following charts are based on water soluble coolant with our standard 25 micron clarity filters. Contact PRAB for flow rates with oil based applications and/or applications requiring alternative micron clarity.

Model	Flow Rate (Water)	Tank Capacity	L	A	B	C	W	H	Pump HP	Paper Motor HP	Paper Width	Notes
PFA-20	5 gpm	20 gal	41"	33"	23"	16"	28"	26"	1/8	1/16	19"	WHEEL
PFA-40	10 gpm	30 gal	47"	39"	23"	16"	28"	26"	1/8	1/16	19"	
PFA-60	15 gpm	35 gal	53"	45"	23"	16"	28"	26"	1/8	1/16	19"	
PFA-80	20 gpm	40 gal	59"	51"	23"	16"	28"	26"	1/4	1/16	19"	
PFA-120	30 gpm	55 gal	59"	51"	31"	16"	36"	29"	1/2	1/10	28"	
PFA-160	40 gpm	90 gal	71"	63"	31"	16"	36"	29"	3/4	1/10	28"	NO WHEEL
PFA-240	60 gpm	115 gal	61"	53"	42"	17"	52"	29"	1	1/4	39"	
PFA-360	95 gpm	170 gal	85"	77"	42"	17"	52"	29"	1	1/4	39"	
PFA-500	130 gpm	220 gal	128"	116"	42"	17"	52"	29"	1 x 2	1/4	39"	
PFA-800	210 gpm	330 gal	201"	187"	42"	17"	53"	30"	2	1/4	39"	

Model	Flow Rate (Water)	Tank Capacity	L	A	B	C	D	E	F	H	W	Pump HP	Paper Motor HP	Paper Width	Notes
MPFA-20	5 gpm	20 gal	41"	33"	23"	16"	22"	28"	1-1/2"	26"	28"	1/8	1/16	19"	WHEEL
MPFA-40	10 gpm	30 gal	47"	39"	23"	16"	22"	28"	2"	26"	28"	1/8	1/16	19"	
MPFA-60	15 gpm	35 gal	53"	45"	23"	16"	22"	28"	2"	26"	28"	1/8	1/16	19"	
MPFA-80	20 gpm	40 gal	59"	51"	23"	16"	22"	28"	2"	26"	28"	1/4	1/16	19"	
MPFA-120	30 gpm	55 gal	59"	51"	31"	16"	23"	30"	3"	29"	36"	1/2	1/10	28"	
MPFA-160	40 gpm	90 gal	71"	63"	31"	16"	24"	30"	3"	29"	36"	3/4	1/10	28"	NO WHEEL
MPFA-240	60 gpm	115 gal	61"	53"	42"	17"	25"	36"	3"	29"	52"	1	1/4	39"	
MPFA-360	95 gpm	170 gal	85"	77"	42"	17"	25"	36"	4"	29"	52"	1	1/4	39"	
MPFA-500	130 gpm	220 gal	128"	116"	42"	17"	25"	36"	5"	29"	52"	1 x 2	1/4	39"	
MPFA-800	210 gpm	330 gal	201"	187"	42"	17"	28"	39"	6"	30"	53"	2	1/4	39"	

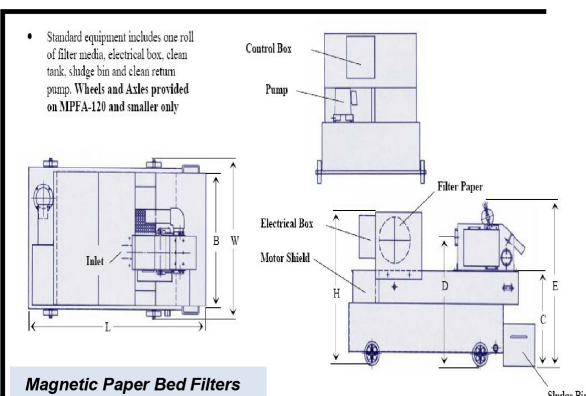
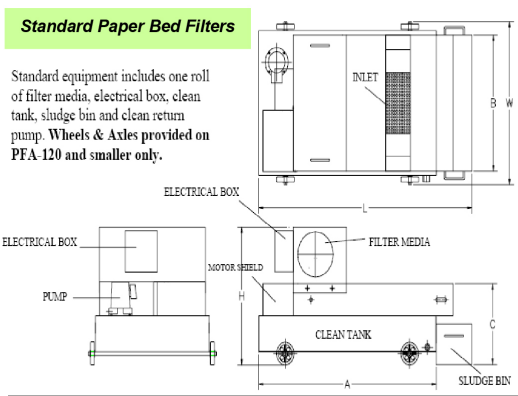

Applications:

- All grinding applications
- General machining
- Honing and gear cutting
- Lathe operations
- Parts washers
- Phosphatizing
- Tube and rolling mills
- Waste treatment
- Wire drawing



Contact us to **request a quote** today

5801 East N Avenue, Kalamazoo, MI 49048

Phone: 1-800-968-7722 | Email: sales@prab.com | Website: prab.com



a global company