

PRAB IN-FLOOR TROUGH CONVEYORS

CONVEYORS STILL OPERATING IN THE FIELD AFTER 57 YEARS

Liquid Tight Construction Ideal for High Volume, Coolant Flow Applications

PRAB In-floor Trough Conveyors transfer all types of metal chips, fines and turnings, wet or dry bushy wads and tramp metal solids with time and energy saving efficiency. The liquid-tight trough construction is ideal for high-volume coolant flow applications.



PRAB Harpoon® Conveyor

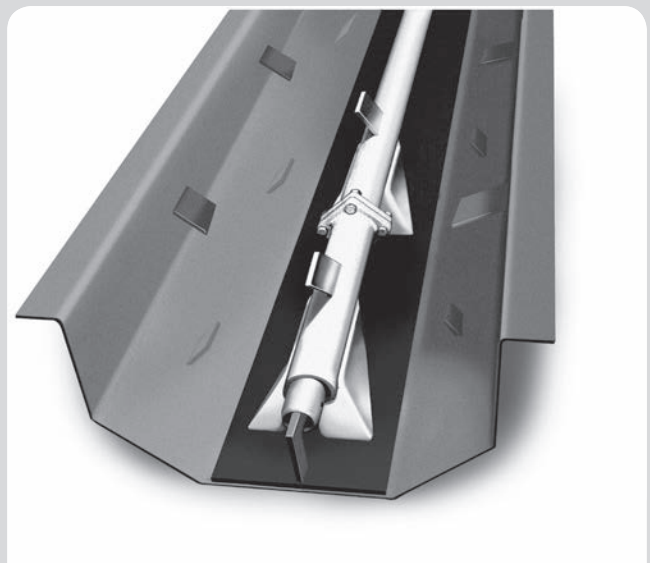

PRAB Push-Bar™ Conveyor

System Features and Benefits:

- Compatible with bushy turnings, chips, fines and tramp metals
- Liquid-tight construction handles high volumes of cutting fluids
- In-floor installation maximizes available plant floor space
- Low power requirement
- Easy maintenance – one moving part
- Quiet operation
- Prefabricated trough sections from 10' to 20'
- Ram sections available in 10' lengths
- Overall runs up to 500'
- Low installation cost per foot
- Optional safety cover plates
- Height by width combinations range from 16" to 36"

"Our process of disposing metal scrap has become more ergonomic and safer."

—Jack Rovon, Martin-Baker



Intersecting Trough Conveyors

Backed by the **PRAB Difference**

PRAB IN-FLOOR TROUGH CONVEYORS

PROVEN TO RAISE PRODUCTIVITY UP TO 60%

Trough Configurations:

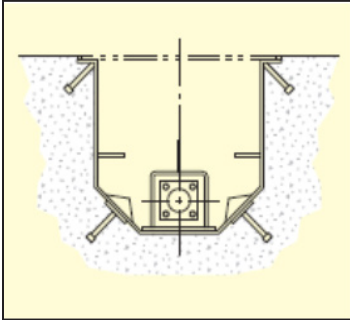

Cast-in-place
standard deck plate

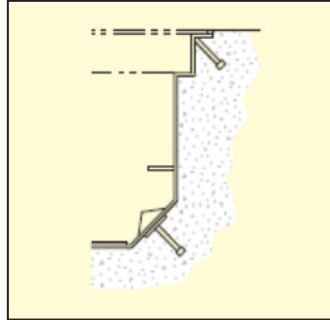

Cast-in-place
heavy-duty deck plate

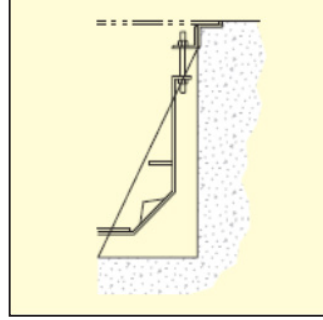

Suspended in pit

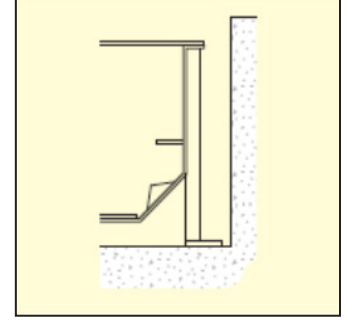

Pit mounted

Trough Models:

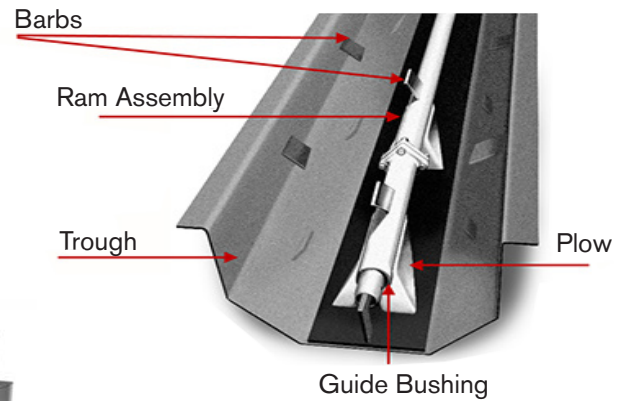
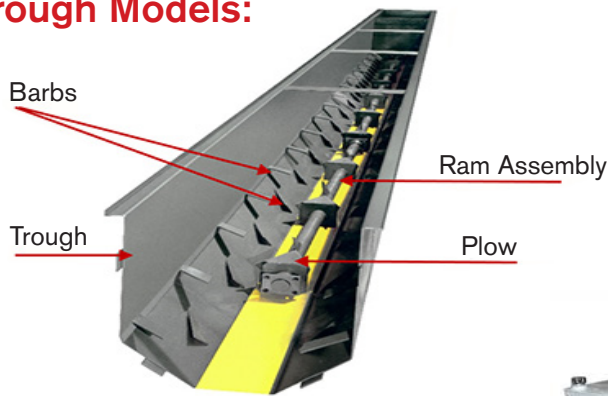

Systems include power-pack

Typical System Layout:

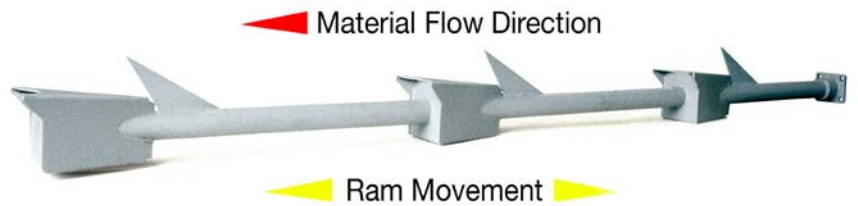
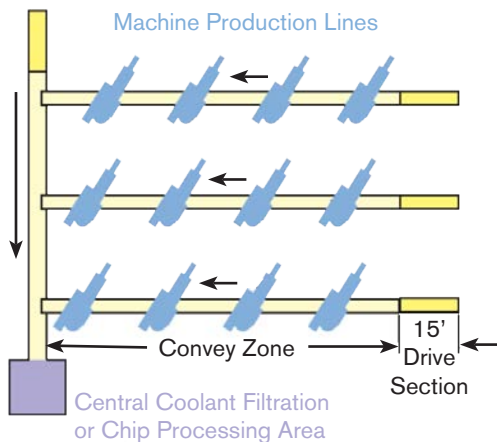

A true performance guarantee ensuring your PRAB equipment achieves the specific results it was designed and manufactured to deliver. And if you need technical support, call us. We are available 24/7.

Contact us to **request a quote** today

5801 East N Avenue, Kalamazoo, MI 49048

Phone: 1-800-968-7722 | Email: sales@prab.com | Website: prab.com

1058-V3-20190617

