

PRAB MAGNETIC SEPARATORS- SS

PROVEN TO REDUCE MACHINE DOWNTIME BY UP TO 50%

10X The Force of Conventional Ferrite Magnets

PRAB SS Magnetic Separators employ high-intensity rare earth magnets within a fully energized rotating drum to continuously remove ferrous particles from the flow of liquid. These systems are often used as a pre-filter to limit contaminants from reaching subsequent filtration equipment.

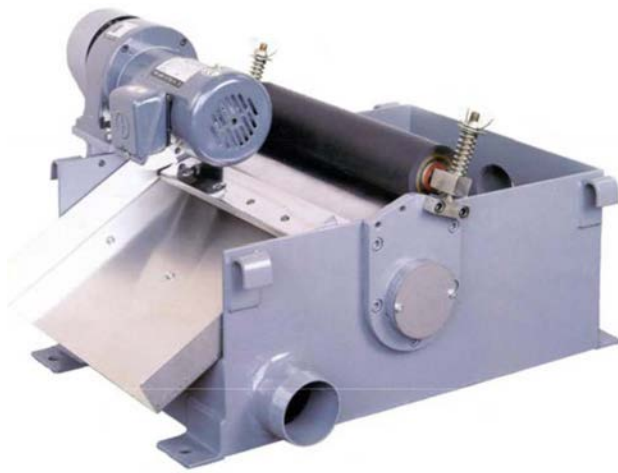

"The reason we purchased PRAB's equipment is because it can keep up with production, it is fully automatic, clean, and very user friendly."

– Gary Sroufe, C&A Tool's multi-spindle "go-to guy"

Rare Earth Super Magnetic Separator: Model SS-360

Features and Benefits:

- Utilizes rare earth magnets that have 10X (3,600 gauss) the force of conventional ferrite magnets
- Easily removes high levels of ferrous contaminants
- Continuous operation
- Prolongs tool life
- Improves surface finish of the component part
- Decreases machine downtime by up to 50%
- Reduces waste disposal
- No consumable media
- Units are available with flow rates from 95 GPM to 315 GPM

Backed by the **PRAB Difference**



PRAB MAGNETIC SEPARATORS- SS

QUICK SHIP: MOST UNITS SHIP IN 5-7 DAYS

Specifications:

Model	Flow Rate	L	W	H	M	N	A	B	D	J	K	Inlet	Outlet	Motor HP
SS-360	95 GPM	32"	24"	10.5"	3"	7"	25"	21"	1/2"	31"	17.5"	4"	4"	1/8
SS-500	130 GPM	32"	32"	10.5"	3"	7"	25"	29"	1/2"	39"	17.5"	5"	5"	1/8
SS-800	210 GPM	32"	48"	10.5"	3"	7"	25"	45"	1/2"	54"	17.5"	5"	5"	1/4
SS-1000	260 GPM	28"	66"	10.5"	3"	7"	26"	56"	1/2"	66"	17.5"	5"	5"	1/4
SS-1200	315 GPM	28"	72"	10.5"	4.5"	7"	26"	68"	1/2"	78"	17.5"	8"	8"	1/4

All dimensions for reference only.

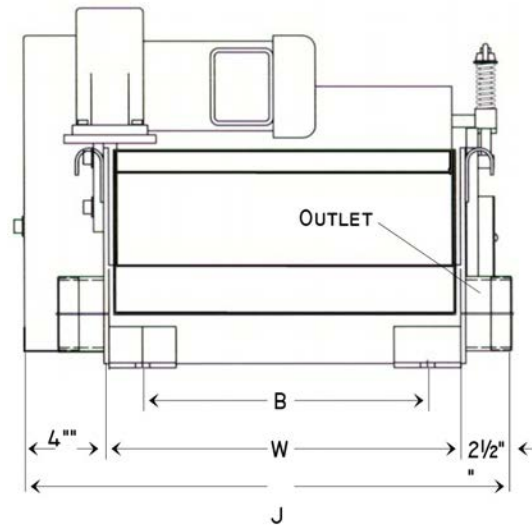
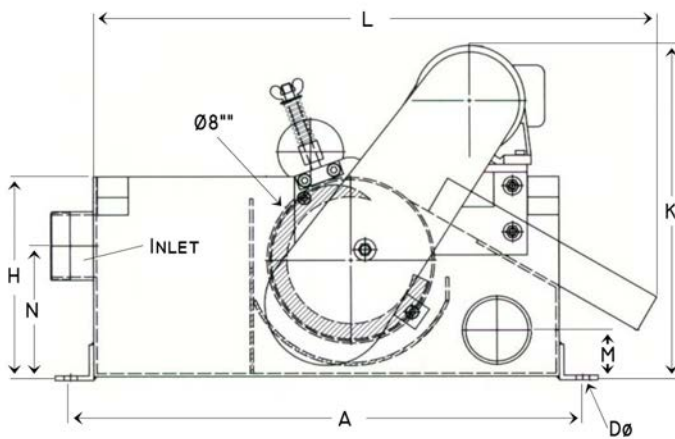

Applications:

- Ferrous Metal Machining
- Production Grinding Applications
- General Machining
- ID & OD Grinding
- Honing
- Gear Cutting
- Lapping
- Gun Drilling
- Lathe Operations
- Wire Drawing



A true performance guarantee ensuring your PRAB equipment achieves the specific results it was designed and manufactured to deliver. And if you need technical support, call us. We are available 24/7.

Contact us to **request a quote** today

5801 East N Avenue, Kalamazoo, MI 49048

Phone: 1-800-968-7722 | Email: sales@prab.com | Website: prab.com

