

PRAB MAGNETIC SEPARATORS- MCJ-A

PROVEN TO REDUCE MACHINE DOWNTIME BY UP TO 50%

Continuously Remove Ferrous Particles from the Flow of Liquid

PRAB MCJ-A Magnetic Separators employ high-intensity ferrite magnets within a fully energized rotating drum to continuously remove ferrous particles from the flow of liquid. These systems are often used as a pre-filter to limit contaminants from reaching subsequent filtration equipment.



"The reason we purchased PRAB's equipment is because it can keep up with production, it is fully automatic, clean, and very user friendly."

– Gary Sroufe, C&A Tool's multi-spindle "go-to guy"

Standard Magnetic Separator - Model: MCJ-80A

Features and Benefits:

- Utilizes ferrite magnets with 1,600 gauss rating for highly effective fluid filtration
- Easily removes high levels of ferrous contaminants
- Continuous operation
- Prolongs tool life
- Improves surface finish of the component part
- Decreases machine downtime by up to 50%
- Reduces waste disposal
- No consumable media
- Units are available with flow rates from 20 GPM to 60 GPM

Backed by the **PRAB Difference**



PRAB MAGNETIC SEPARATORS- MCJ-A

QUICK SHIP: MOST UNITS SHIP IN 5-7 DAYS

Specifications:

MCJ-80A to MCJ-160A Drawing

MCJ-240A Drawing

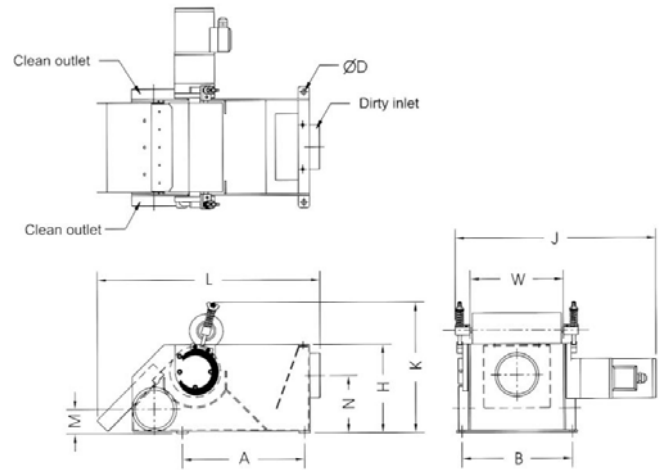
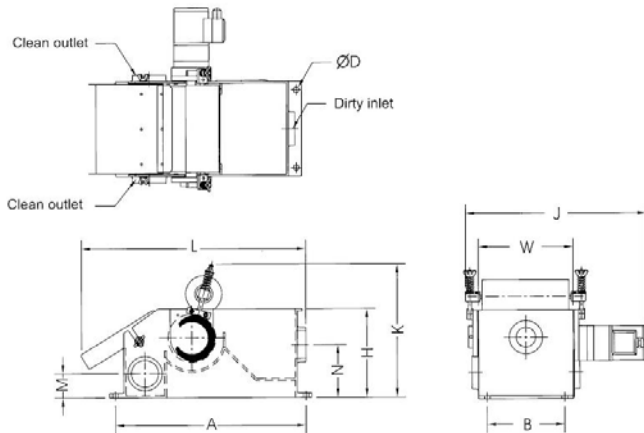

Model	Flow Rate	L	W	H	M	N	A	B	D	J	K	Inlet NPT	Outlet NPT	Motor HP
MCJ-80A	20 GPM	18.25"	9.5"	7.25"	2"	4.3"	15.7"	8.3"	7/16"	17.5"	11"	2"	2.5"	1/16
MCJ-120A	30 GPM	19"	10.6"	8.7"	2.5"	5.5"	15.7"	9"	7/16"	18.6"	12.4"	3"	3"	1/10
MCJ-160A	40 GPM	19"	14"	8.7"	2.5"	5.5"	15.7"	12.3"	7/16"	21.9"	12.4"	3"	3"	1/10
MCJ-240A	60 GPM	19.8"	17.7"	7.9"	2.5"	4.9"	10.8"	19.2"	7/16"	27.1"	11.6"	3"	3"	1/10

Applications:

- Ferrous Metal Machining
- Production Grinding Applications
- General Machining
- ID & OD Grinding
- Honing
- Gear Cutting
- Lapping
- Gun Drilling
- Lathe Operations



A true performance guarantee ensuring your PRAB equipment achieves the specific results it was designed and manufactured to deliver. And if you need technical support, call us. We are available 24/7.

Contact us to **request a quote** today

5801 East N Avenue, Kalamazoo, MI 49048

Phone: 1-800-968-7722 | Email: sales@prab.com | Website: prab.com



a  Global company