

PRAB MAGNETIC SEPARATORS- MCA

PROVEN TO REDUCE MACHINE DOWNTIME BY UP TO 50%

Continuously Remove Ferrous Particles from the Flow of Liquid

PRAB MCA Magnetic Separators employ high-intensity ferrite magnets within a fully energized rotating drum to continuously remove ferrous particles from the flow of liquid. These systems are often used as a pre-filter to limit contaminants from reaching subsequent filtration equipment.



Features and Benefits:

- Utilizes ferrite magnets with 1,200 gauss rating for highly effective fluid filtration
- Easily removes high levels of ferrous contaminants
- Continuous operation
- Prolongs tool life
- Improves surface finish of the component part
- Decreases machine downtime by up to 50%
- Reduces waste disposal
- No consumable media
- Units are available with flow rates up to 315 GPM

"The reason we purchased PRAB's equipment is because it can keep up with production, it is fully automatic, clean, and very user friendly."

– Gary Sroufe, C&A Tool's multi-spindle "go-to guy"

Backed by the **PRAB Difference**



PRAB MAGNETIC SEPARATORS- MCA

QUICK SHIP: MOST UNITS SHIP IN 5-7 DAYS

Specifications:

Model	Flow Rate	L	W	H	M	N	A	B	D	J	K	Inlet	Outlet	Motor HP
MCA-20	5 GPM	18"	5"	8"	2.5"	6"	16"	4"	1/2"	9"	12"	1-1/2"	1-1/2"	1/16
MCA-40	10 GPM	18"	6"	8"	2.5"	6"	16"	4"	1/2"	10"	12"	2"	2"	1/16
MCA-60	15 GPM	18"	8"	8"	2"	6"	16"	7"	1/2"	12"	12"	2"	2"	1/16

Drawing for MCA Models 20 to 60

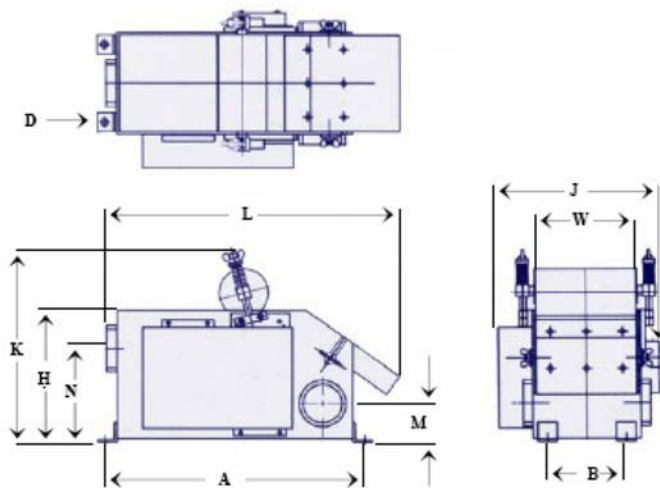

Drawing for MCA Models 360 to 1200

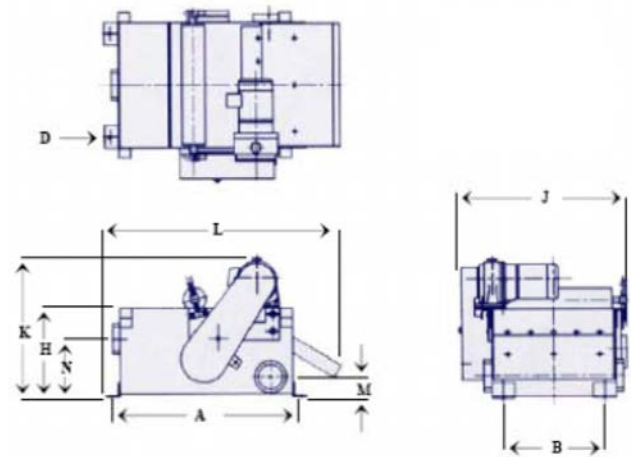

Model	Flow Rate	L	W	H	M	N	A	B	D	J	K	Inlet	Outlet	Motor HP
MCA-360	95 GPM	32"	24"	12"	3"	8"	26"	21"	5/8"	31"	19"	1-1/2"	4"	1/8
MCA-500	130 GPM	32"	32"	12"	3.5"	8"	26"	29"	5/8"	39"	19"	5"	5"	1/8
MCA-800	210 GPM	32"	48"	12"	3.5"	8"	26"	44"	5/8"	54"	19"	5"	5"	1/4
MCA-1000	260 GPM	32"	60"	16"	5"	11"	33"	56"	5/8"	66"	22"	6"	6"	1/4
MCA-1200	315 GPM	32"	72"	20"	6"	15"	32"	68"	5/8"	78"	27"	8"	8"	1/4

Applications:

- Ferrous Metal Machining
- Production Grinding Applications
- General Machining
- ID & OD Grinding
- Honing
- Gear Cutting
- Lapping
- Gun Drilling
- Lathe Operations



A true performance guarantee ensuring your PRAB equipment achieves the specific results it was designed and manufactured to deliver. And if you need technical support, call us. We are available 24/7.

Contact us to **request a quote** today

5801 East N Avenue, Kalamazoo, MI 49048

Phone: 1-800-968-7722 | Email: sales@prab.com | Website: prab.com

