

PRAB PRESSURIZED BAG FILTER HOUSING

A QUALITY FILTER VESSEL FOR LOWER PRESSURE APPLICATIONS

Description

PRAB's 100 PSI Size 1 and 2 liquid bag filter housings offer a quality filter vessel for lower pressure applications. The Size #1 & Size #2 100 PSI filter vessels effectively remove dirt, metal fines, chips, pipe scale and other contaminants from process liquids such as water, coolant, chemical and petroleum products. Quality construction and design ensure protection for all downstream equipment.

Vessel Construction - The Size #1 and Size #2 filter vessels are designed for operating up to 100 PSI at 300° F. The housing design provides a large sump area at the bottom of the basket for dirt and scale accumulation. This design utilizes the filter more efficiently and prolongs the filter element life.

An O-ring seal eliminates particulate bypass between the basket and seat. Optional mesh-lined strainer baskets and O-rings are available. Please consult your PRAB filtration specialist for further information.

A vent and gauge port in the housing lid and a drain port in the housing allow for faster evacuation and filling. Permanently piped housing can be opened with a simple tool without disturbing the piping. The lid features a closure with 3 swing bolts and eye nuts that make it easy to open and close without having to remove any hardware.

As a standard finish, all vessels are blast cleaned and painted inside and out with a 2-part epoxy. Stainless steel vessels are supplied with a satin finish.

Features and Benefits:

- Carbon steel or 304 stainless steel construction
- 100 PSI pressure rating
- Low pressure drop
- Quick swing closure with eye nuts
- Buna seals – lid and basket
- Differential, drain, and vent ports
- Adjustable support legs
- 304 stainless steel strainer basket
- 2" Female NPT connection



Pressurized Bag Filter Housing



A true performance guarantee ensuring your PRAB equipment achieves the specific results it was designed and manufactured to deliver. And if you need technical support, call us. We are available 24/7.

Backed by the **PRAB Difference**



PRAB PRESSURIZED BAG FILTER HOUSING

A QUALITY FILTER VESSEL FOR LOWER PRESSURE APPLICATIONS

Filter Vessel Dimensions

	SIZE #1	Size #2
A	30.6"	42.1"
B	16.0"	27.5"
C	24.5"	36.0"
D	21.0"	32.6"

All dimensions for reference only.

Specifications

- 3-bolt swing closure with vent and gauge port in housing lid
- Connections are 2" NPT with side inlet and bottom outlet
- Housing supplied with two differential pressure ports to measure differential pressure across filter bag
- Two-part epoxy finish applied on carbon steel vessels maximizes life of housing
- Stainless steel vessels supplied with satin finish.
- Basket manufactured from 304 stainless steel with 9/64" perforations acts as a strainer or accepts a 1 or 2 size liquid bag filter
- Buna O-ring seals basket to support
- Adjustable tripod legs supplied with housing
- Vessels rated at 100 pounds per square inch

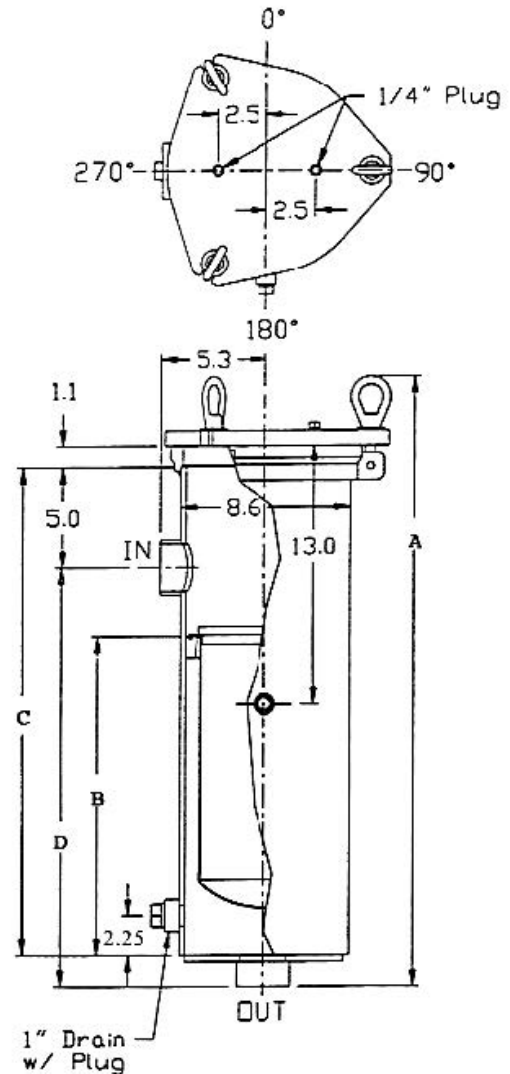

Also available are PRAB's Mag Bags for use with this filter housing. Consult your PRAB filtration specialist for more information.

Filter Vessel	Basket	Connection Type	Optional Connection	Material	PSI
Size #1	15"	2" NPT	2"-4" Flanged	Carbon Steel or Stainless Steel	100
Size #2	30"	2" NPT	2"-4" Flanged	Carbon Steel or Stainless Steel	100

Contact us to **request a quote** today

5801 East N Avenue, Kalamazoo, MI 49048

Phone: 1-800-968-7722 | Email: sales@prab.com | Website: prab.com

