

PRAB MAGNETIC SEPARATORS - MSA

ADVANCED SEPARATION UTILIZING RARE EARTH MAGNETS

8X The Force of Conventional Ferrite Magnets

PRAB MSA Magnetic Separators employ high-intensity rare earth magnets within a fully energized rotating drum to continuously remove ferrous particles from the flow of liquid. These systems are often used as a pre-filter to limit contaminants from reaching subsequent filtration equipment.



Model MSA: Rare Earth Magnetic Separator



Magnetic Separator Mounted on Paper Bed Filter

Features and Benefits:

- Utilizes rare earth magnets that have 8X (3,000 gauss) the force of conventional ferrite magnets
- Easily removes high levels of ferrous contaminants
- Continuous operation
- Prolongs tool life
- Improves surface finish of the component part
- Decreases machine downtime by up to 50%
- Reduces waste disposal
- No consumable media
- Units are available with flow rates up to 60 GPM

A true performance guarantee ensuring your PRAB equipment achieves the specific results it was designed and manufactured to deliver. And if you need technical support, call us. We are available 24/7.



5801 East N Avenue, Kalamazoo, MI 49048
Phone: 1-800-968-7722 | Fax: 1-269-349-2477 | sales@prab.com

prab.com



PRAB MAGNETIC SEPARATORS - MSA

COST-EFFECTIVE CLARIFIER WITH A PROVEN DESIGN

Specifications:

Model	Flow Rate	L	W	H	M	N	A	B	D	J	K	Inlet	Outlet	Motor HP
MSA-20	5 GPM	19"	6"	7"	2"	4"	15"	5"	1/2"	15"	12"	1-1/2"	1-1/2"	1/16
MSA-40	10 GPM	19"	7"	7"	2"	4"	15"	6"	1/2"	16"	12"	2"	2"	1/16
MSA-60	15 GPM	19"	8"	7"	2"	4"	15"	7"	1/2"	17"	12"	2"	2"	1/16
MSA-80	20 GPM	19"	10"	8"	2.5"	5"	15"	9"	1/2"	19"	12-1/2"	2"	2-1/2"	1/16
MSA-120	30 GPM	19"	13"	8"	2.5"	5"	15"	12"	1/2"	22"	12-1/2"	2-1/2"	3"	1/10
MSA-180	45 GPM	19"	17"	8"	2.5"	5"	15"	16"	1/2"	26"	12-1/2"	3"	3"	1/10
MSA-240	60 GPM	19"	23"	8"	2.5"	5"	15"	22"	1/2"	32"	12-1/2"	3"	3"	1/8

All dimensions for reference only.

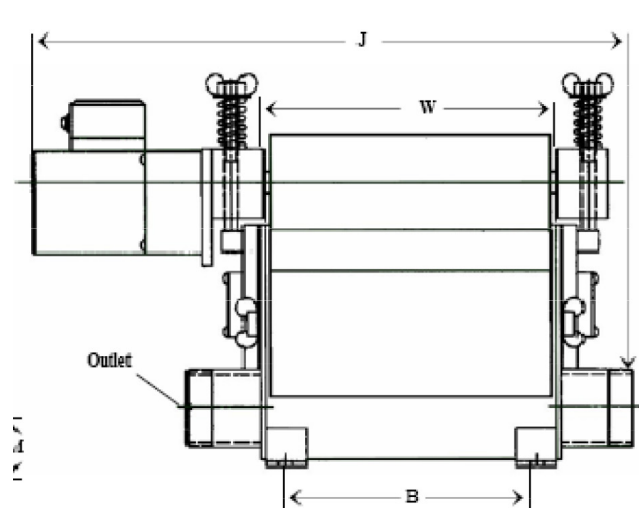
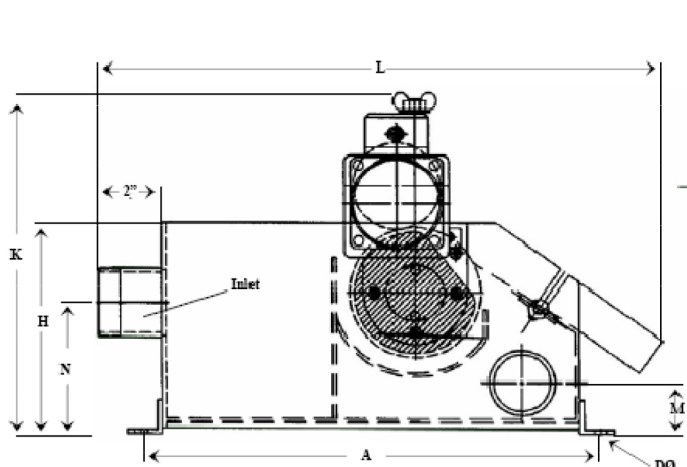

Applications:

- Ferrous Metal Machining
- Production Grinding Applications
- General Machining
- ID & OD Grinding
- Honing
- Gear Cutting
- Lapping
- Gun Drilling
- Lathe Operations
- Wire Drawing

5801 East N Avenue, Kalamazoo, MI 49048
 Phone: 1-800-968-7722 | Fax: 1-269-349-2477 | sales@prab.com

prab.com

PF1320

